

MFS25PNF

MAYTAG® COMMERCIAL
ENERGY ADVANTAGE™
SOFT-MOUNT, HIGH-SPEED EXTRACTOR



LEGENDARY MAYTAG DEPENDABILITY

Maximizing your equipment investment for over a half century.

MICROPROCESSOR CONTROLS

Maytag® microprocessor controls offer 15 preprogrammed cycles, plus the capability to create multiple unique cycles. Also, one-touch cycle selection and multilingual readouts make these controls easy for everyone to operate.



CHEMICAL INJECTION SYSTEM

Designed to make chemical installation faster, simpler and more precise, the Maytag® Commercial Laundry Chemical Injection System features easy-access connections on the outside of the machine. This eliminates the need for having to open up the washer on routine visits. This system also provides chemical supply companies and the machine's users with clear visibility on how detergent, bleach, softener and other chemicals are being dispersed.

FLEXIBLE INSTALLATION

Maytag® soft-mount, high-speed extractors feature a suspension system that allows for more flexibility and does not require special foundations for installations.

FOR YOUR OPERATION:

- Inverter Drive Technology For Longer Life
- Up to 300 G's In Final Spin, Reducing Dry Time
- Easy-To-Operate Microprocessor Controls
- Adjustable Water Temperatures And Levels
- Manual 3-Bay Detergent And Softener Dispenser
- Ability To Use Powdered Or Liquid Chemical Supply
- 8 Chemical Supply Signals
- Extra-Large Drain Valve
- Extra-Large Door And Handle

BUILT-TO-LAST™ FEATURES:

- Heavy-Duty Latch And Door Handle
- Durable Sealed Bearings
- Rugged Frame And Cabinet
- Easy Service Access

SPINS

UP TO 300 G'S
TO EXTRACT MORE WATER

EASY TO USE

**EXTERNAL
HOOKUPS**
FOR CHEMICAL
INJECTION

LAUNDRY SOLUTIONS
YOU CAN *DEPEND* ON.



OUR COMMITMENT TO DEPENDABLE QUALITY

At Maytag, we believe durable goods should remain just that. That's why every Maytag® product is constructed of the highest-quality materials and with the utmost in precision craftsmanship. It's also why we stand behind our equipment with solid service and support from our professional Maytag laundry suppliers. Simply put, when you choose Maytag® products, you ensure your peace of mind.

www.maytagcommerciallaundry.com



MFS25PNF

**MAYTAG® COMMERCIAL ENERGY ADVANTAGE™
SOFT-MOUNT,
HIGH-SPEED EXTRACTOR**

Maytag® Energy Advantage™ Soft-Mount, High-Speed Extractor MICROPROCESSOR CONTROL

WASHER SPECIFICATIONS	
MODEL	MFS25PNF
MOTOR	
Inverter drive	•
Variable speed	•
HP (kw)	2 (1.5)
Voltage	208 – 240V Single-Phase/Three-Phase
Export models — volts (Hz)	208 – 480 (50)
BREAKER SIZE — amps	15
SPEED	
Wash speed — rpm	48
Extract speed — maximum rpm	1000
Extract speed — maximum g-force	300
WATER INLET/HOSE	
Water inlet — in. (mm)	.75 (19)
Operating pressure — psi (bar)	14.5 – 116 (1 – 8)
Drain size — in. (mm)	3.0 (76) O.D.
CAPACITY	
Lbs. (kg)	25 (10)
Cylinder volume — cu. ft. (liters)	3.3 (93)
Cylinder diameter — in. (mm)	20.88 (530)
Cylinder depth — in. (mm)	16.50 (419)
CABINET	
Stainless Steel	•
APPROXIMATE WEIGHT	
Crated — lbs. (kg)	662 (300)
Uncrated — lbs. (kg)	607 (275)
DIMENSIONS	
A) Height — in. (mm)	44.88 (1140)
B) Width — in. (mm)	26 (660)
C) Depth — in. (mm)	30.91 (785)
D) Depth including door handle and air vent on back — in. (mm)	34.05 (865)
Door Opening — in. (mm)	11.25 (286)
See specific instructions for proper installation. Because of continuous product improvement, Maytag reserves the right to change specifications without notice.	

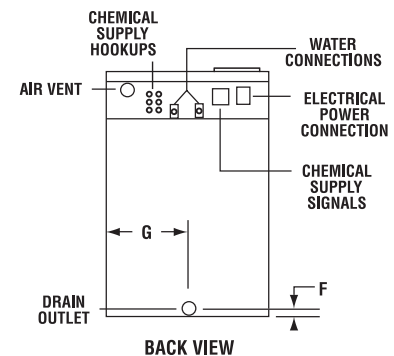
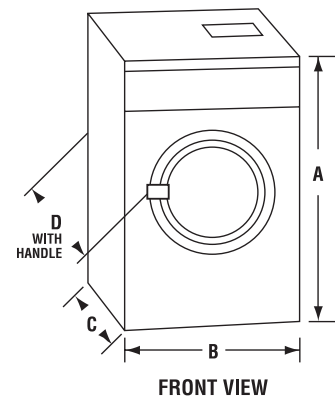

NEW YORK CITY
M.E.A.

MAYTAG® LIMITED WARRANTY

2 YEARS ON ALL PARTS

**5 YEARS ON SHELL, WELDED FRAME ASSEMBLY,
BASKET, SHAFT ASSEMBLY, BEARINGS AND SEALS**

For a period from the date of original purchase through the time listed above, the designated parts that fail in normal commercial use will be repaired or replaced free of charge for the part itself, with the owner paying all other costs, including labor, transportation and customs duty. Chemical damage is excluded from all warranty coverage. See complete warranty for details.

For more information and pricing, contact:

Equipment Marketers

100 Melrose Avenue
Cherry Hill, NJ 08003

Phone: 800.223.1376

Fax: 856.428.5477

www.equipmentmarketers.net

maytag@equipmentmarketers.net